

# Continuous Hydrolyzor

## 连续水解罐

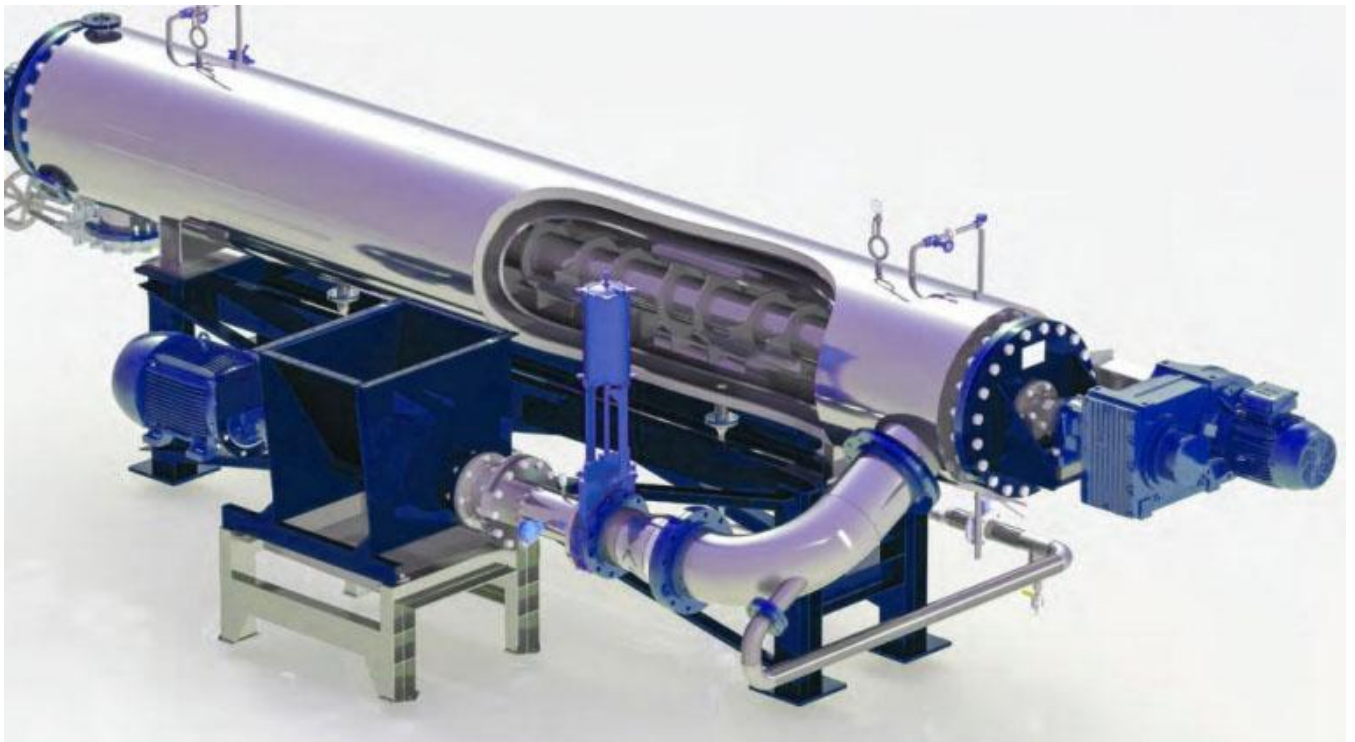

### Introduction

The Sensitar Continuous Hydrolyzor converts poultry feathers or hog hair into a highly nutritional animal feed. Every part of the Continuous Hydrolyzor that touches product is constructed of stainless steel. Proven screw feeder technology provides a position seal for the hydrolyzing vessel, and a steam-heated agitator shaft ensures optimum heat transfer and steam efficiency. Steam-saving discharge assembly maintains internal pressure and proper operation level in the shell.

### Advantages

- Available in carbon or stainless steel or a combination of both
- Low maintenance, only need to maintain a pressurized packing gland
- Special main shaft designed to ensure efficient
- Continuous automated operation.
- Low steam consumption.

### 设备简介

鑫正达连续水解罐可将家禽羽毛或猪毛转变成高营养的动物饲料。大容量连续水解器接触产品的每个部分均由不锈钢制成。成熟的螺杆进料器技术为水解容器提供了位置密封，并且蒸汽加热的搅拌器轴确保了最佳的热传递和蒸汽效率。节省蒸汽的排放组件可维持壳体内部的压力和适当的操作水平。

### 优点

- 可用碳或不锈钢材料或两者结合使用
- 低维护，仅需维护一个加压填料压盖
- 特殊主轴设计，确保高效
- 连续自动化操作
- 蒸汽消耗低

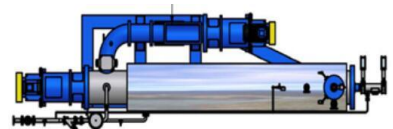

## Equipment Structure

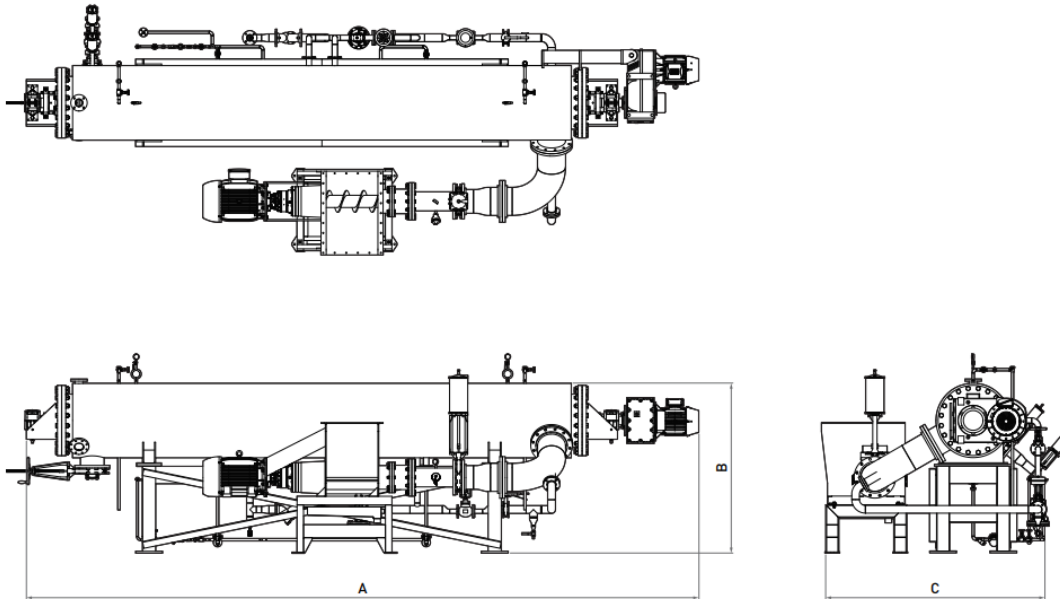

## Technical Specifications

Technical Specification	Unit	Type		
		CFH-50	CFH-75	CFH-120
Capacity	t/h	5.0	7.5	12.0
A inlet	mm	925 × 405	925 × 405	925 × 445
A	mm	9250	10250	10950
B	mm	3100	3200	3450
C	mm	2600	2650	3000
Weight	mt	15	16	18
Power, feeder	KW	37	45	55
Power, hydroliser	KW	18.5	22	30

SHANDONG SENSITAR MACHINERY MANUFACTURING CO.,LTD.

Address: Xiangzhou Industrial Park,  
Zhucheng City, Shandong Province.

Tel: +86-536-6053905 Fax: +86-536-6053915

Http://www.xzdjx.net

E-mail: xzdjx@xzdjx.com

**山东鑫正达机械制造有限公司**

地址：山东省诸城市相州工业园

电话：0536-6053905 传真：0536-6053915

网址：www.xzdjx.com.cn

邮箱：xzdjx@xzdjx.com



服务热线  
400-0667-958